



ETA-Danmark A/S
Göteborg Plads 1
DK-2150 Nordhavn
Tel. +45 72 24 59 00
Internet www.etadanmark.dk

Authorised and notified according
to Article 29 of the Regulation (EU)
No 305/2011 of the European
Parliament and of the Council of 9
March 2011

MEMBER OF EOTA



European Technical Assessment ETA-21/0049 of 2021/01/01

I General Part

Technical Assessment Body issuing the ETA and designated according to Article 29 of the Regulation (EU) No 305/2011: ETA-Danmark A/S

Trade name of the construction product:

Pyrocoustic®

Product family to which the above construction product belongs:

Fire Stopping and Sealing Product:
• Penetration Seals

Manufacturer:

FSi Ltd
Westminster Industrial Estate
Tamworth Road
Measham
Leicestershire
DE12 7DS

Manufacturing plant:

FSi Ltd
Westminster Industrial Estate
Tamworth Road
Measham
Leicestershire
DE12 7DS

This European Technical Assessment contains:

27 pages including 3 annexes which form an integral part of the document

This European Technical Assessment is issued in accordance with Regulation (EU) No 305/2011, on the basis of:

EAD 350454-00-1104, September 2017.

This version replaces:

-

Translations of this European Technical Assessment in other languages shall fully correspond to the original issued document and should be identified as such.

Communication of this European Technical Assessment, including transmission by electronic means, shall be in full [except the confidential Annex(es) referred to above]. However, partial reproduction may be made with the written consent of the issuing Technical Assessment Body. Any partial reproduction has to be identified as such.

I. SPECIFIC PARTS OF THE EUROPEAN TECHNICAL ASSESSMENT

1 Technical description of the product

- 1) Pyrocoustic® is an acrylic based sealant used to form a penetration seal around insulated or uninsulated metallic pipes and electrical cables, to reinstate the fire resistance performance of wall and floor constructions where they have been provided with apertures for the penetration of services.
- 2) Pyrocoustic® is supplied in liquid form contained within 310 ml & 380 ml cartridges, 600 ml foils or in 5, 10, 20 or 25 litre tubs. The sealant is gunned or trowelled into the aperture in or between the separating element/elements to a specified depth using various backing materials.
- 3) Certain seals require FSi Thermal Defense Wrap in addition, used to insulate the service. The Thermal Defense Wrap is a 6 mm thick foil faced ceramic based insulation material, installed externally to the Pyrocoustic® sealant as detailed in Annex A.
- 4) FSi Ltd has submitted a written declaration that Pyrocoustic® does not contain substances which have to be classified as dangerous according to article 59 (1, 10) of the Regulation (EC) No 1907/2006 (REACH).

In addition to the specific clauses relating to dangerous substances contained in this European technical Assessment, there may be other requirements applicable to the products falling within its scope (e.g. transposed European legislation and national laws, regulations and administrative provisions). In order to meet the provisions of the Construction Products Regulation, these requirements need also to be complied with, when and where they apply.

- 5) The use category of Pyrocoustic® in relation to BWR 3 (Hygiene, health and environment) is IA2

2 Specification of the intended uses of the product in accordance with the applicable European Assessment Document (Hereinafter EAD): EAD 350454-00-1104

Detailed information and data is given in Annex A.

- 1) The intended use of system Pyrocoustic® is to reinstate the fire resistance performance of flexible and rigid wall constructions and rigid floor constructions where they are penetrated by insulated or uninsulated metallic pipes and electrical cables.
- 2) The specific elements of construction that the system Pyrocoustic® may be used to provide a penetration seal in, are as follows:
 - a. Flexible walls: The wall must have a minimum thickness of 75 mm and comprise steel studs or timber studs* lined on both faces with minimum 1 layer of 12.5 mm thick boards.
 - b. Rigid walls: The wall must have a minimum thickness of 75 mm and comprise concrete, aerated concrete or masonry with a minimum density of 650 kg/m³.
 - c. Rigid floors: The floor must have a minimum thickness of 150 mm and comprise aerated concrete or concrete with a minimum density of 650 kg/m³.

* no part of the penetration seal may be closer than 100 mm to a stud, the cavity must be closed between the penetration seal and the stud, and minimum 100 mm of insulation of class A1 or A2 according to EN 13501-1 must be provided within the cavity between the penetration seal and the stud.

The supporting construction must be classified in accordance with EN 13501-2 for the required fire resistance period.

- 3) The System Pyrocoustic® may be used to provide a penetration seal with specific single insulated metal pipes, uninsulated metal pipes and with specific electrical cables, single or in a bundle (for details see Annex A).
- 4) Apertures in the separating element shall be maximum \varnothing 350 mm or 300 x 300 mm. The annular space/gap around the services shall be infilled with Pyrocoustic® sealant and in some cases utilising various backing materials. For full details, see Annex A.
- 5) The provisions made in this European Technical Assessment are based on an assumed working life of the Pyrocoustic® of 25 years, provided that the conditions laid down in the product datasheet for the packaging/transport/ storage/installation/use/repair are met. The indications given on the working life cannot be interpreted as a guarantee given by the producer or the Technical Assessment Body, but are to be regarded only as a means for choosing the right products in relation to the expected economically reasonable working life of the works.
- 6) Type X: Intended for use in conditions exposed to weathering and all lower classes.

3 Performance of the product and references to the methods used for its assessment

Product-type: Intumescent sheet		Intended use: Penetration Seal
	Essential characteristic	Product performance
BWR 2 Safety in case of fire		
	Reaction to fire	No performance assessed
	Resistance to fire	Annex A
BWR 3 Hygiene, health and environment		
	Air permeability	Annex B
	Water permeability	No performance assessed
	Content, emission and/or release of dangerous substances	Use categories: IA2 Declaration of manufacturer
BWR 4 Safety in use		
	Mechanical resistance and stability	No performance assessed
	Resistance to impact/movement	No performance assessed
	Adhesion	No performance assessed
	Durability	Type X
BWR 5 Protection against noise		
	Airborne sound insulation	Annex C
BWR 6 Energy economy and heat retention		
	Thermal properties	No performance assessed
	Water vapour permeability	No performance assessed

4 ASSESSMENT AND VERIFICATION OF CONSTANCY OF PERFORMANCE (HEREINAFTER AVCP) SYSTEM APPLIED, WITH REFERENCE TO ITS LEGAL BASE

According to the decision 1999/454/EC – Commission Decision of date 22nd June 1999 on the procedure for attesting the conformity of construction products pursuant to Article 20(2) of Council Directive 89/106/EEC as regards fire stopping, fire sealing and fire protective products, published in the Official Journal of the European Union (OJEU) L178/52 of 14/07/1999, (see <https://eur-lex.europa.eu/oj/direct-access.html>) of the European Commission¹, as amended, the system(s) of assessment and verification of constancy of performance (see Annex V to Regulation (EU) No 305/2011) given in the following table(s) applies (apply).

Product(s)	Intended use(s)	Level(s) or class(es)	System(s)
Fire stopping and Fire Sealing Products	For fire compartmentation and/or fire protection or fire performance	Any	1

5 Technical details necessary for the implementation of the AVCP system, as provided for in the applicable EAD

Technical details necessary for the implementation of the AVCP system are laid down in the control plan deposited at ETA-Danmark A/S prior to CE marking

Issued in Copenhagen on 2021-01-01 by



Thomas Bruun
Managing Director, ETA-Danmark

¹ Official Journal of the European Communities L178/52 of 14/7/1999

ANNEX A – Resistance to Fire Classification – Pyrocoustic®

A.1 Flexible and rigid wall constructions with wall thickness of minimum 75 mm

A.1.1 Double sided penetration seal with cables

Penetration Seal: Cables (single) fitted centrally within the aperture, sealed with Pyrocoustic® sealant to both sides of the wall, backed with various backing materials. Minimum separation between penetration seals 200 mm (a2).

Construction details:

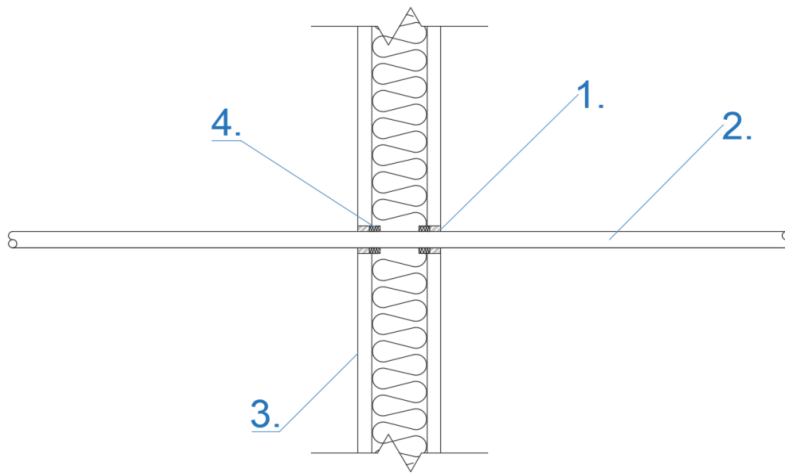

Key:

1. Pyrocoustic® Sealant
2. Single Cable
3. Flexible Wall
4. Backing Material

A.1.1.1

Penetration Service	Depth (mm)	Maximum Aperture Size (mm)	Backing Material	Classification
D1 cable*	10	100 Ø	PE backing rod, glass wool, stone wool or ceramic wool	E 60, EI 45
B cable*	12	25 Ø	Stone wool or ceramic wool (10 mm 45kg/m ³)	E 90, EI 60

* As defined in EN 1366-3: 2009, Annex A

A.1.2 Double sided penetration seal with cables bunches

Penetration Seal: Cables bunches fitted centrally within the aperture, sealed with Pyrocoustic® sealant to both sides of the wall, backed with various backing materials. Minimum separation between penetration seals 200 mm (a2).

Construction details:

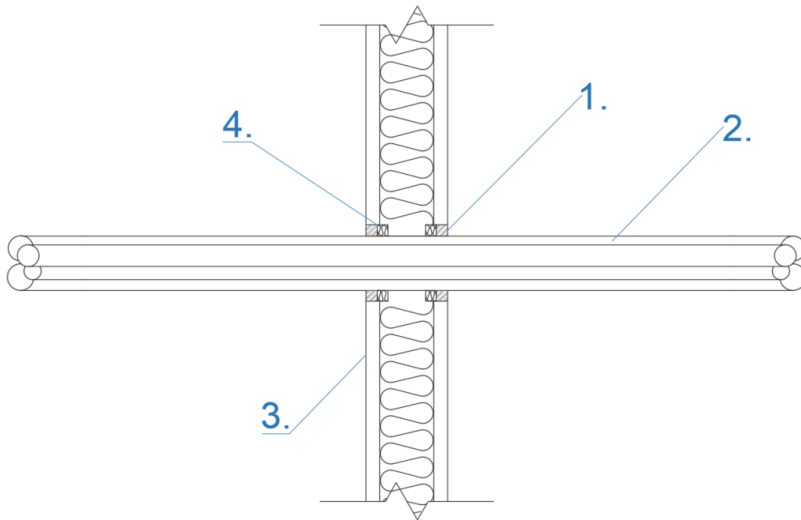

Key:

1. Pyrocoustic® Sealant
2. Single Bunch
3. Flexible Wall
4. Backing Material

A.1.2.1

Penetration Service	Depth (mm)	Maximum Aperture Size (mm)	Backing Material	Classification
Telecoms cables ≤ 21 mm \varnothing in cable bunch ≤ 100 mm \varnothing	10	120 \varnothing	PE backing rod, glass wool, stone wool or ceramic wool	E 60, EI 45

A.1.3 Double sided penetration seal with cable trunking

Penetration Seal: Cables trunkings filled with cables penetrating through an aperture through a flexible or rigid wall construction. The aperture is filled with S-Line Pillows and sealed with Pyrocoustic® sealant to both sides of the wall, backed with various backing materials. Minimum separation between penetration seals 200 mm (a2).

Construction details:

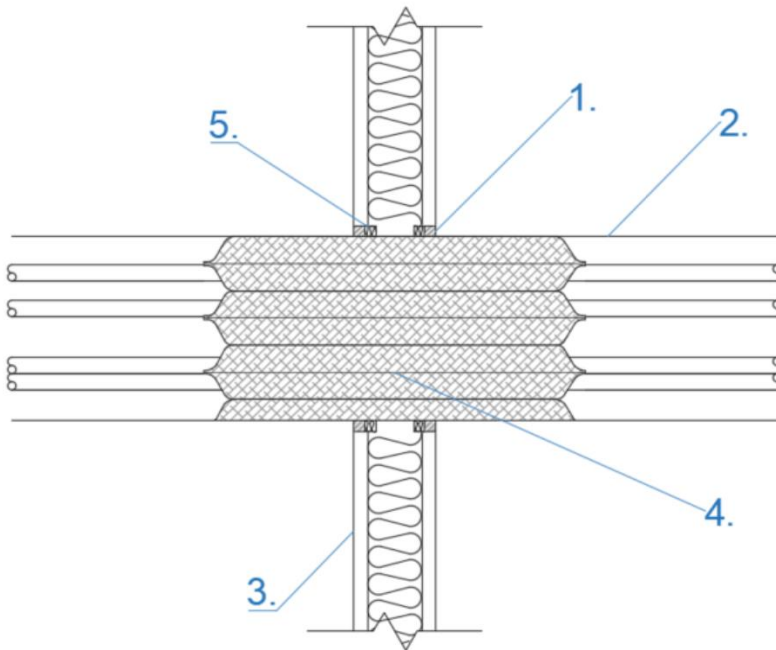

Key:

1. Pyrocoustic® Sealant
2. Metal Trunking filled with cables
3. Flexible Wall
4. S-Line Pillows
5. Backing Material

A.1.3.1

Penetration Service	Depth (mm)	Maximum Aperture Size (mm)	Backing Material	Minimum Distance to Edge of Aperture (mm)	Classification
Steel trunking up to 150 mm x 150 mm	10	170 x 170	PE backing rod, glass wool, stone wool or ceramic wool	0	E 60, EI 20
Steel trunking up to 50 mm x 50 mm	10	70 x 70	PE backing rod, glass wool, stone wool or ceramic wool	0	E 60, EI 45

A.1.4 Double sided penetration seal with cable trays

Penetration Seal: Cables trays with cables penetrating through a flexible or rigid wall construction and sealed with Pyrocoustic® sealant to both sides of the wall, backed with various backing materials. Minimum separation between penetration seals 200 mm (a2).

Construction details:

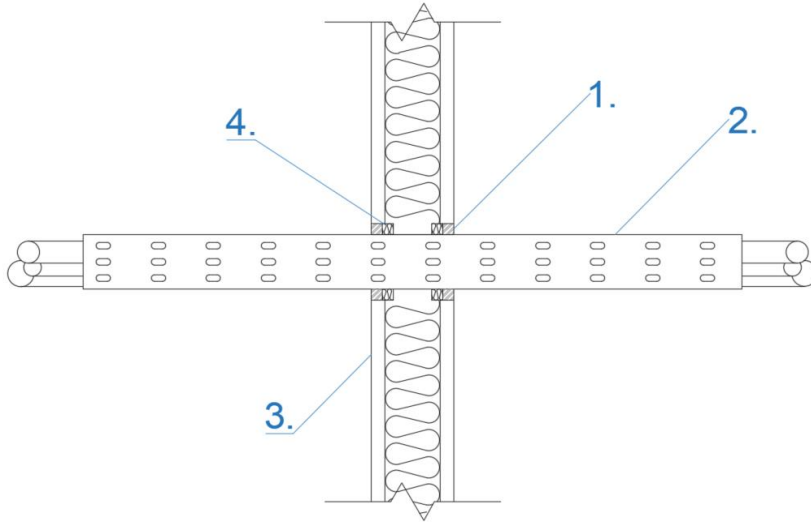

Key:

1. Pyrocoustic® Sealant
2. Cable Tray
3. Flexible Wall
4. Backing Material

A.1.4.1

Penetration Service	Depth (mm)	Maximum Aperture Size (mm)	Backing Material	Minimum Distance to Edge of Aperture (mm)	Classification
Steel cable tray ≤450 mm wide loaded with cables ≤21 mm Ø + C1, C2, C3 cables*	10	470 x 100	PE backing rod, glass wool, stone wool or ceramic wool	0	E 60, EI 20
Steel cable tray ≤450 mm wide loaded with cables ≤21 mm Ø + C1, C2, C3 cables* with insulation ≤40 mm thick ≤45kg/m ³ , ≤400 mm either side of the wall (L/I)	10	470 x 100	PE backing rod, glass wool, stone wool or ceramic wool	0	EI 45

* As defined in EN 1366-3: 2009, Annex A

A.1.5 Double side penetration seal with metallic pipes

Penetration Seal: Metallic pipes (single) fitted centrally within the aperture, sealed with Pyrocoastic® sealant to both sides of the wall, backed with various backing materials. Minimum separation between penetration seals 200 mm (a2).

Construction details:

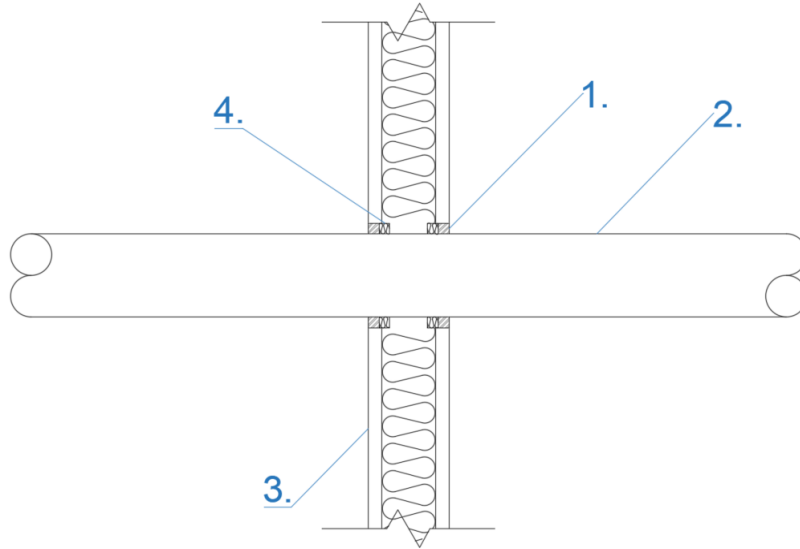

Key:

1. Pyrocoastic® Sealant
2. Metal Pipe
3. Flexible Wall
4. Backing Material

A.1.5.1

Penetration Service	Depth (mm)	Annular (mm)	Backing Material	Classification
Copper pipe ≤15 mm diameter/ 0.7-14.2 mm wall thickness	12	5-10	Stone wool or ceramic wool (≥10mm ≥45kg/m³)	E 90 C/U, C/C, EI 60 C/U, C/C
Copper or Steel pipe 15-54 mm diameter/ 1.2-14.2 mm wall thickness*				E 90 C/U, C/C
Steel pipe 15 mm diameter/ 1-14.2 mm wall thickness				EI 90 C/U, C/C
Steel pipe 15-76 mm diameter/ 2-14.2 mm wall thickness*				E 90 C/U, C/C, EI 20 C/U, C/C
Steel pipe 325 mm diameter/ 17.5 mm wall thickness, insulated with stone wool ≥40 mm thick, ≥45kg/m³ (LI) min. 400 mm length to both faces	10	25 (0 distance from aperture edge)	PE backing rod, glass wool, stone wool or ceramic wool	E 60 C/U, C/C, EI 30 C/U, C/C

* See below graphs for interpolated pipe sizes and permitted wall thicknesses

Copper or Steel Pipes - C/U

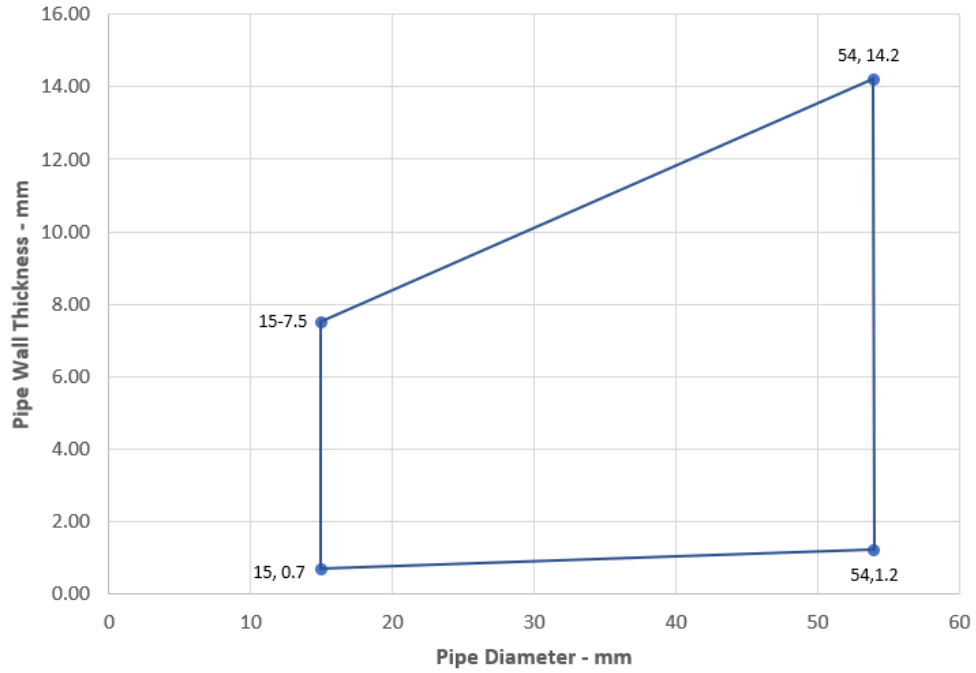

Steel Pipes - C/U

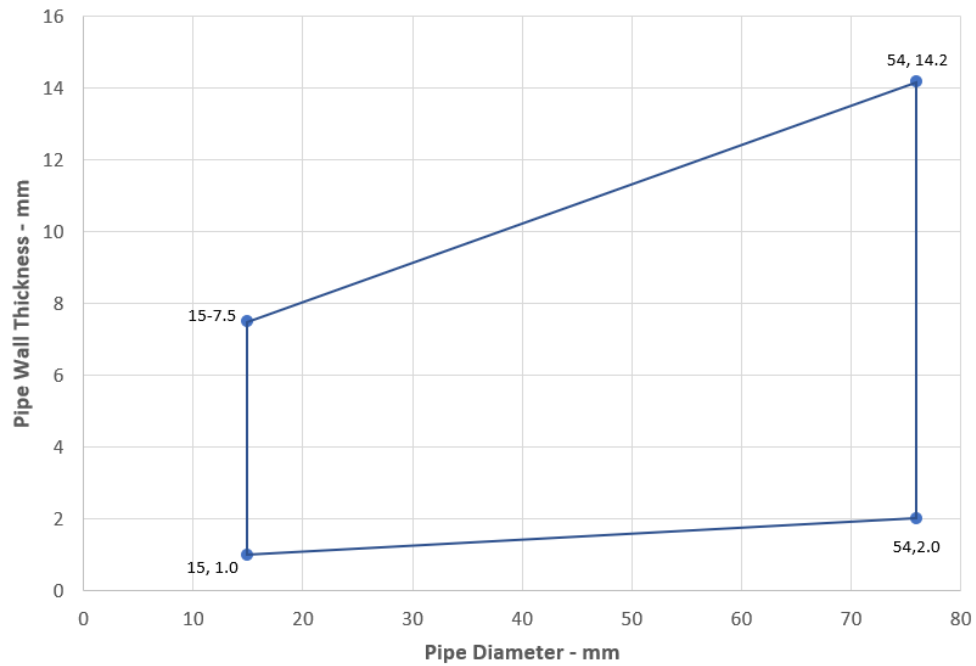

A.1.6 Double side penetration seal with insulated metallic pipes

Penetration Seal: Insulated metallic pipes (single) fitted at any position within the aperture, sealed with Pyrocoustic® sealant to both sides of the wall, backed with various backing materials. Minimum separation between penetration seals 200 mm (a2).

Construction details:

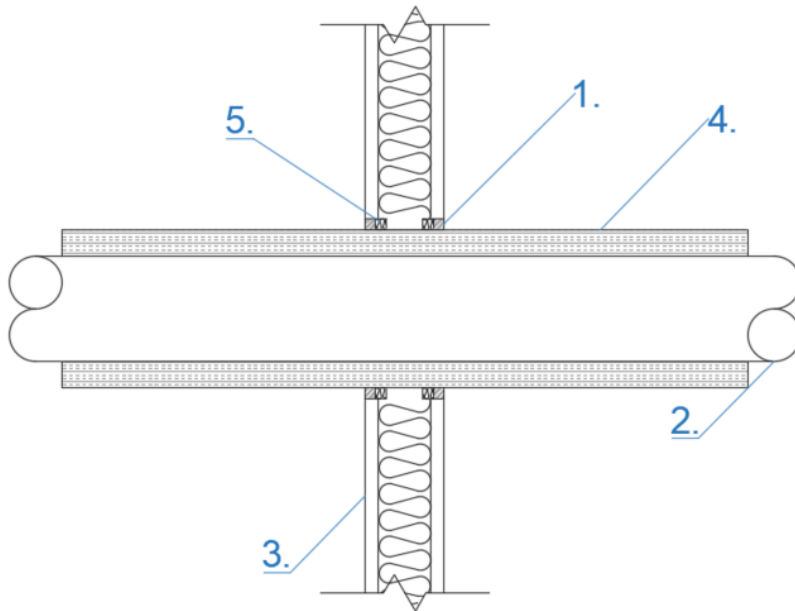

Key:

1. Pyrocoustic® Sealant
2. Metal Pipe
3. Flexible Wall
4. Stone Wool Insulation
5. Backing Material

A.1.6.1

Penetration Service	Depth (mm)	Maximum Aperture Size (mm)	Backing Material	Minimum Distance to Edge of Aperture (mm)	Classification
Copper or steel pipe 159 mm diameter/ 2- 14.2 mm wall thickness insulated with stone wool ≥50 mm thick, ≥90kg/m ³ (C/S)	10	10	PE backing rod, glass wool, stone wool or ceramic wool	0	E 60 C/U, C/C, EI 45 C/U, C/C

A.2 Flexible and rigid wall constructions with wall thickness of minimum 100 mm

A.2.1 Double sided penetration seal with cables and conduits

Penetration Seal: Cables and conduits fitted within the aperture, sealed with Pyrocoustic® sealant to both sides of the wall, backed with Stone wool or ceramic wool (20 mm 45kg/m³). Minimum separation between penetration seals 200 mm (a2).

Construction details:

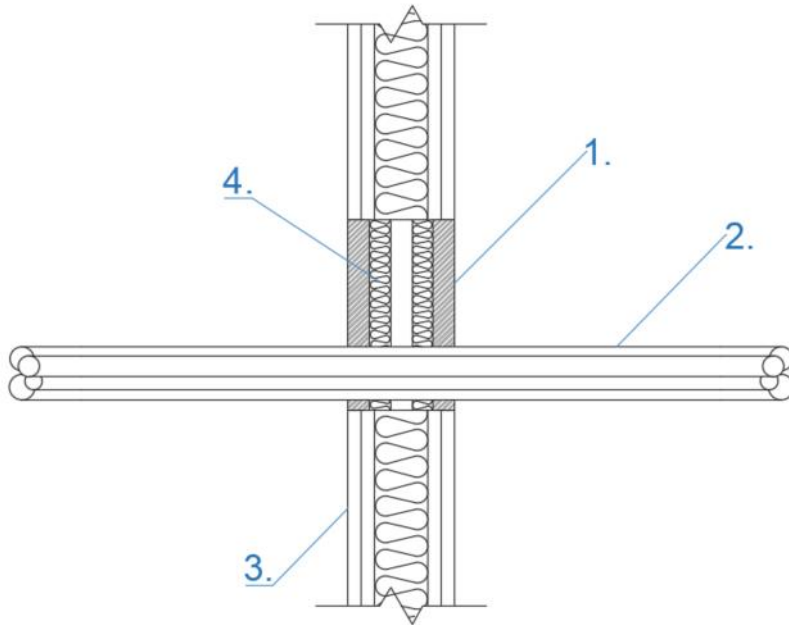

Key:

1. Pyrocoustic® Sealant
2. Cables
3. Flexible Wall
4. Backing Material

A.2.1.1

Penetration Service	Depth (mm)	Maximum Aperture Size (mm)	Backing Material	Minimum Distance to Edge of Aperture (mm)	Classification
Cable bunch ≤100 mm Ø	20	180 x 180	Stone wool or ceramic wool (20 mm 45kg/m ³)	10	EI 120
PVC conduits ≤16 mm Ø					EI 120
Steel/Copper conduits ≤16 mm Ø					E 120, EI 20
Cables ≤50 mm Ø					E 90, EI 60
Cables ≤21 mm Ø					EI 120

A.2.2 Double sided penetration seal with metallic pipes

Penetration Seal: Metallic pipes (single) fitted centrally within the aperture, sealed with Pyrocoustic® sealant to both sides of the wall, backed with various backing materials. Minimum separation between penetration seals 200 mm (a2).

Construction details:

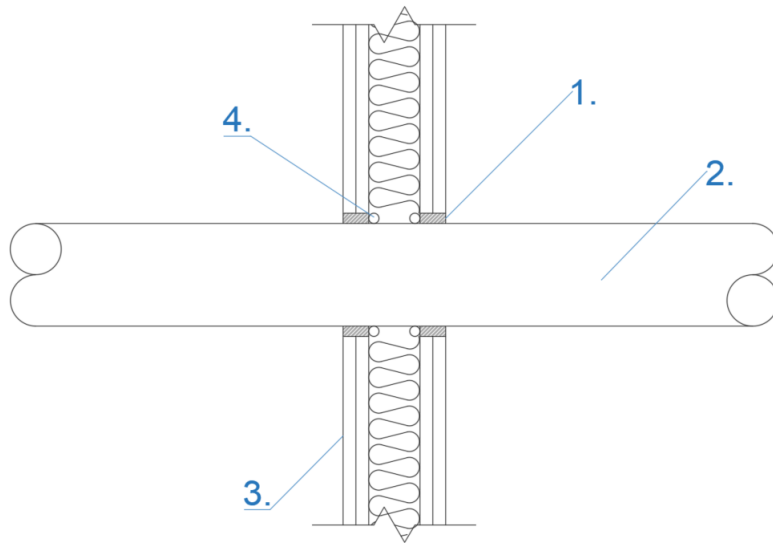

Key:

1. Pyrocoustic® Sealant
2. Metal Pipe
3. Flexible Wall
4. Backing Material

A.2.2.1

Penetration Service	Depth (mm)	Annular (mm)	Backing Material	Classification
Steel pipe 42 mm diameter/ 2.8-14.2 mm wall thickness	25	10	PE backing rod, glass wool, stone wool or ceramic wool	E 120 C/U, C/C, EI 45 C/U, C/C
Steel pipe 42-114mm diameter/ 3-14.2mm wall thickness*				E 120 C/U, C/C, EI 20 C/U, C/C

* See below graphs for interpolated pipe sizes and permitted wall thicknesses

Steel Pipes - C/U

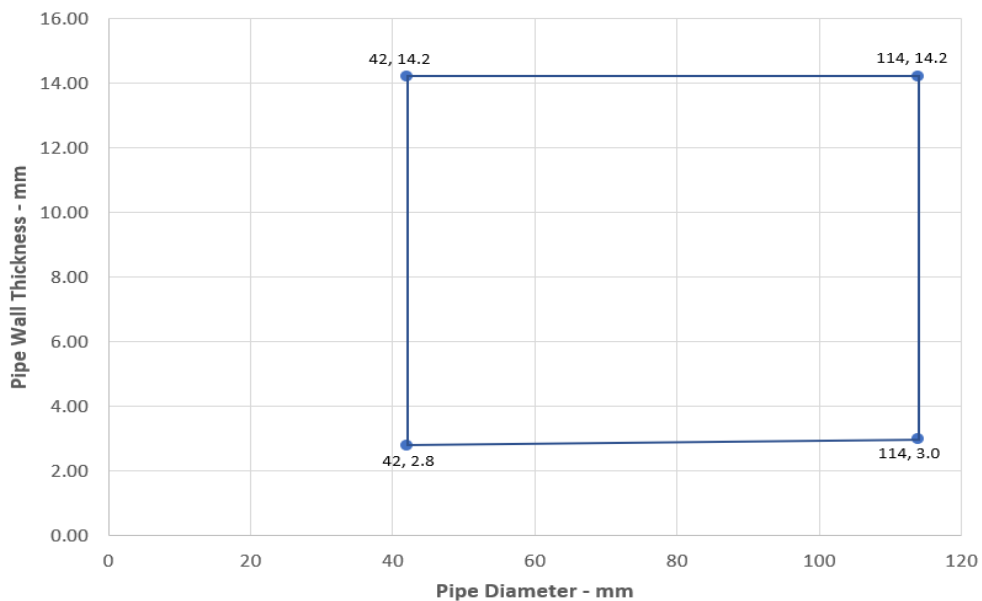

A.3 Flexible and rigid wall constructions with wall thickness of minimum 120 mm

A.3.1 Double sided penetration seal with cable trays

Penetration Seal: Cables trays with cables penetrating through a flexible or rigid wall construction and sealed with Pyrocoustic® sealant to both sides of the wall, backed with various backing materials. Minimum separation between penetration seals 200 mm (a2).

Construction details:

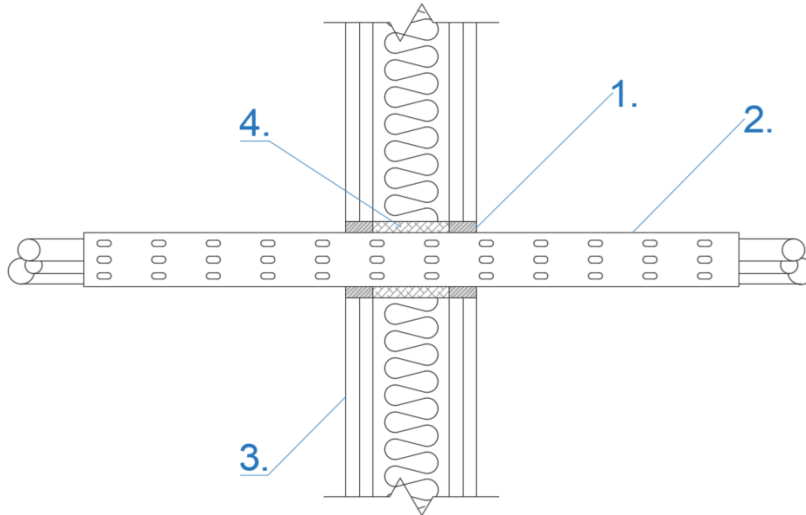

Key:

1. Pyrocoustic® Sealant
2. Cable Tray/Cables
3. Flexible Wall
4. Backing Material

A.3.1.1

Penetration Service	Depth (mm)	Maximum Aperture Size (mm)	Backing Material	Minimum Distance to Edge of Aperture (mm)	Classification
Steel cable tray ≤450 mm wide loaded with cables ≤21 mm Ø	25	490 x 100	Stone wool or ceramic wool (≥35 mm ≥80kg/m ³)	20	E 120, EI 90
C1, C2, D1 and D2 Cables*	25	200 x 100	PE backing rod, glass wool, stone wool or ceramic wool	20	E 90, EI 60

* As defined in EN 1366-3: 2009, Annex A

A.3.2 Double sided penetration seal with metallic pipes

Penetration Seal: Metallic pipes (single) fitted centrally within the aperture, sealed with Pyrocoustic® sealant to both sides of the wall, backed with various backing materials. Minimum separation between penetration seals 200 mm (a2).

Construction details:

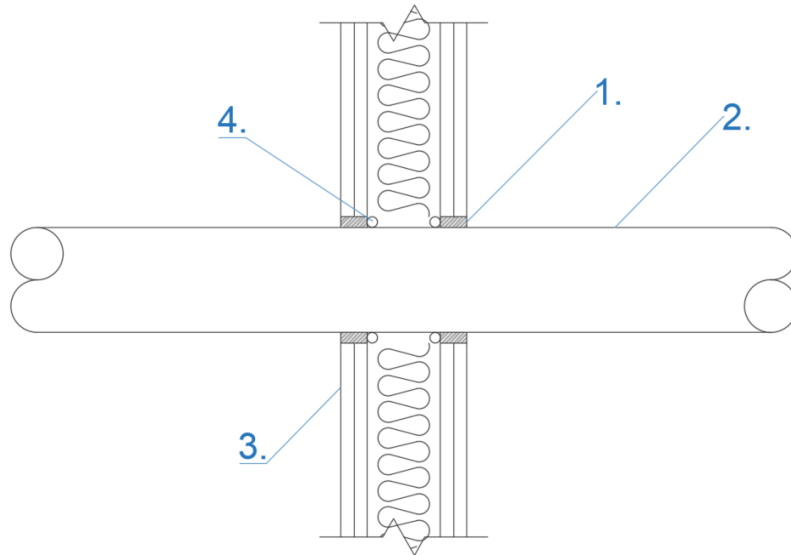

Key:

1. Pyrocoustic® Sealant
2. Metal Pipe
3. Flexible Wall
4. Backing Material

A.3.2.1

Penetration Service	Depth (mm)	Annular (mm)	Backing Material	Classification
Copper or steel pipe 15-40 mm diameter/ 0.8-14.2 mm wall thickness	25	10	PE backing rod, glass wool, stone wool or ceramic wool	E 120 C/U, C/C, EI 15 C/U, C/C
Copper or steel pipe 40-159 mm diameter/ 1.8-14.2 mm wall thickness*				E 120 C/U, C/C,
Copper or steel pipe 40 mm diameter/ 0.8-14.2mm wall thickness insulated with FSi TDW to both sides of the wall at 300 mm (L/I)				E 120 C/U, C/C, EI 90 C/U, C/C
Copper or steel pipe 40-159 mm diameter/ 1.8-14.2 mm wall thickness insulated with FSi TDW to both sides of the wall at 300 mm (L/I)*				E 120 C/U, C/C, EI 20 C/U, C/C

* See below graphs for interpolated pipe sizes and permitted wall thicknesses

Copper or Steel Pipes - C/U

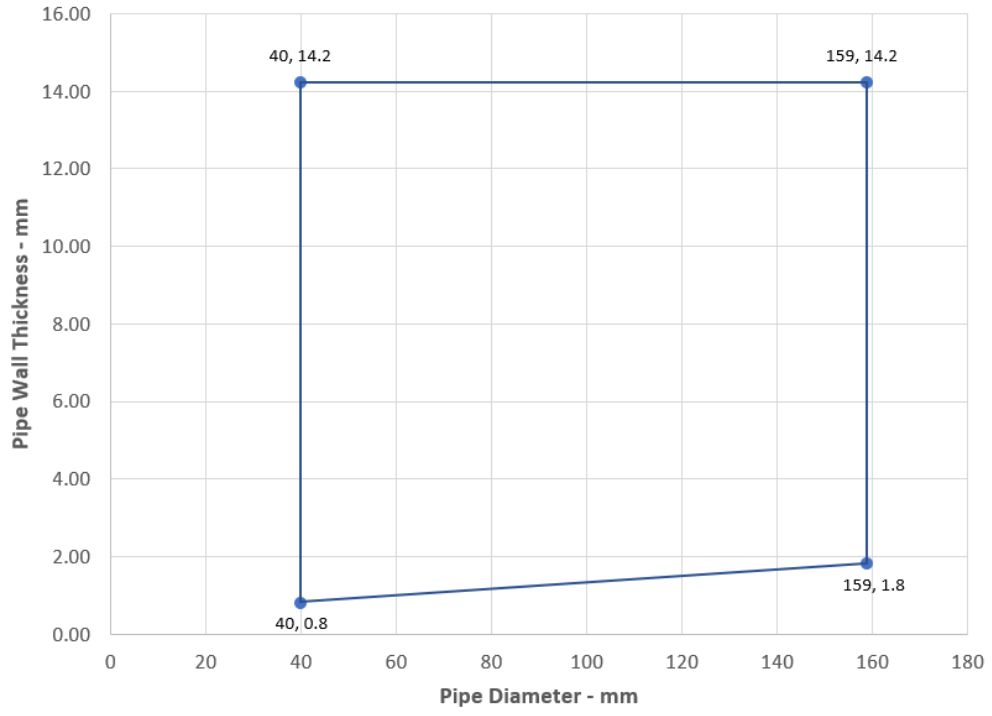

A.4 Rigid wall constructions with wall thickness of minimum 150 mm

A.4.1 Double side penetration seal with metallic pipes

Penetration Seal: Metallic pipes (single) fitted at any position within the aperture, sealed with Pyrocoustic® sealant to either side of the wall, backed with Stone wool or ceramic wool ($\geq 144 \text{ mm } \geq 80 \text{ kg/m}^3$). Minimum separation between penetration seals 200 mm (a2).

Construction details:

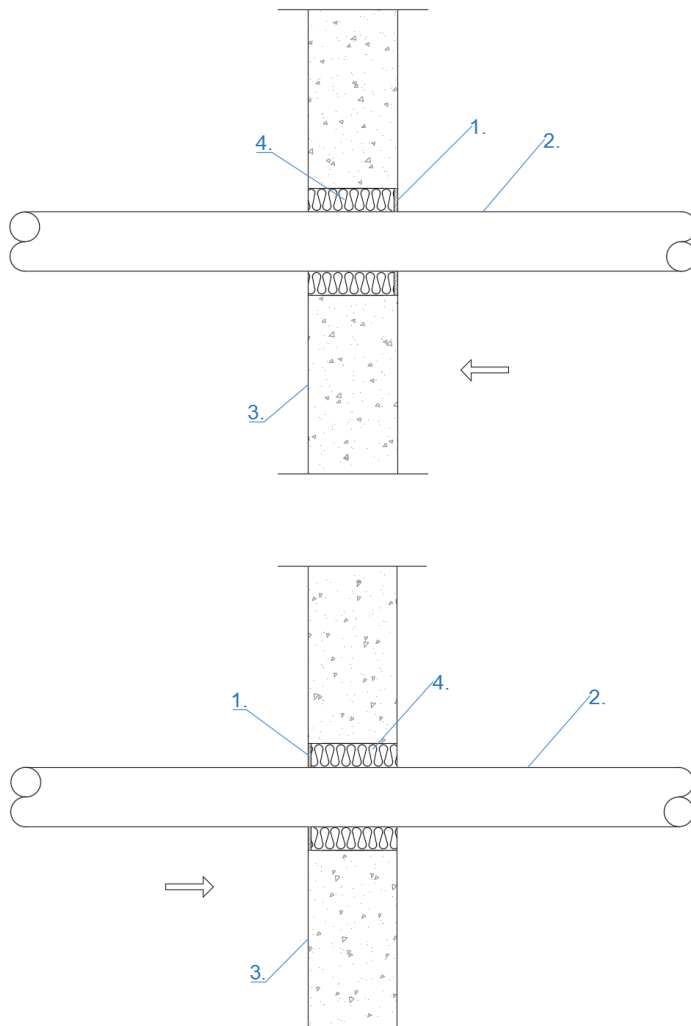

Key:

1. Pyrocoustic® Sealant
2. Metal Pipe
3. Rigid Wall
4. Backing Material

A.4.1.1

Penetration Service	Depth (mm)	Maximum Aperture Size (mm)	Backing Material	Minimum Distance to Edge of Aperture (mm)	Classification
Steel pipe 40-152 mm diameter/ 2.5-14.2mm wall thickness*	6	Pipe $\varnothing + 50$ mm	Stone wool or ceramic wool ($\geq 144 \text{ mm } \geq 80 \text{ kg/m}^3$)	0	E 240 C/C
Steel pipe 40 mm diameter/ 1.5-14.2 mm wall thickness	6	Pipe $\varnothing + 50$ mm	Stone wool or ceramic wool ($\geq 144 \text{ mm } \geq 80 \text{ kg/m}^3$)	0	E 240 C/C, EI 120 C/C

* See below graphs for interpolated pipe sizes and permitted wall thicknesses

Steel Pipes - C/C

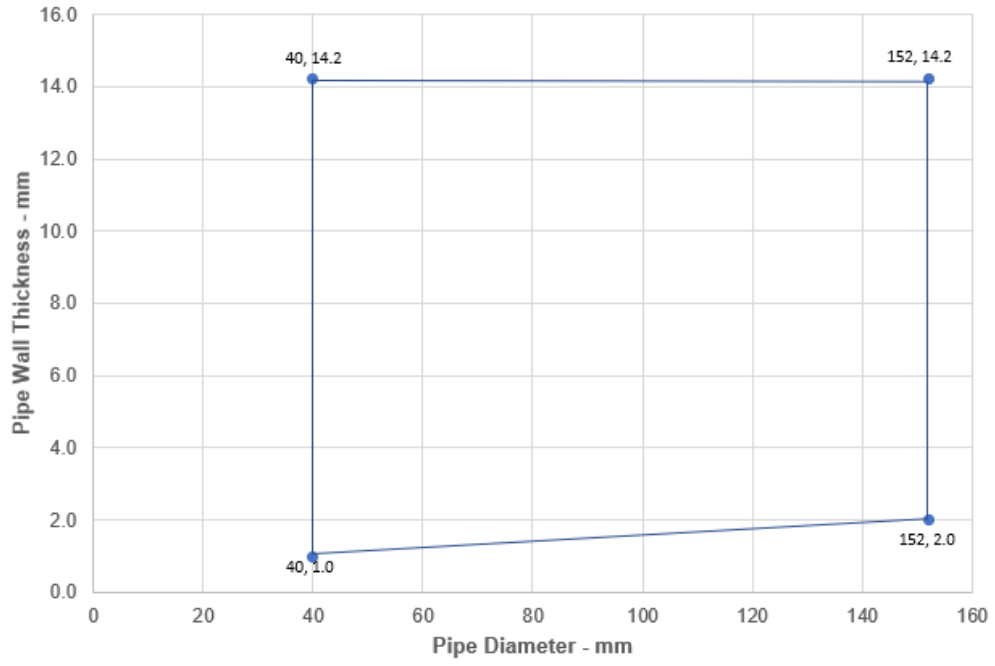

A.4.2 Double side penetration seal with insulated metallic pipes

Penetration Seal: Insulated metallic pipes (single) fitted at any position within the aperture, sealed with Pyrocoustic® sealant to both sides of the wall, backed with various backing materials. Minimum separation between penetration seals 200 mm (a2).

Construction details:

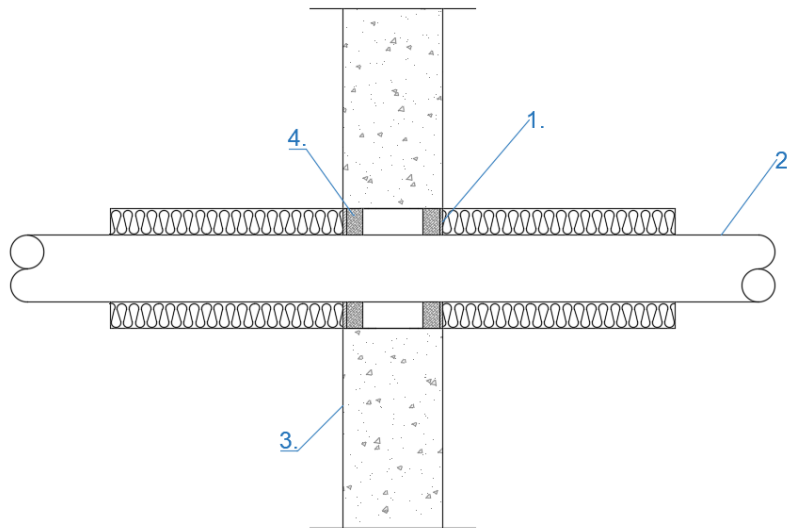

Key:

1. Pyrocoustic® Sealant
2. Metal Pipe
3. Rigid Wall
4. Backing Material

A.4.2.1

Penetration Service	Depth (mm)	Maximum Aperture Size (mm)	Backing Material	Minimum Distance to Edge of Aperture (mm)	Classification
Copper or steel pipe 35-159mm diameter/ 2-14.2 mm wall thickness insulated with stone wool 50 mm thick 100kg/m ³ (C/I)*	5	Pipe \varnothing + 55 mm	PE backing rod, glass wool, stone wool or ceramic wool	0	EI 240 C/U, C/C

* See below graphs for interpolated pipe sizes and permitted wall thicknesses

Copper or Steel Pipes - C/U

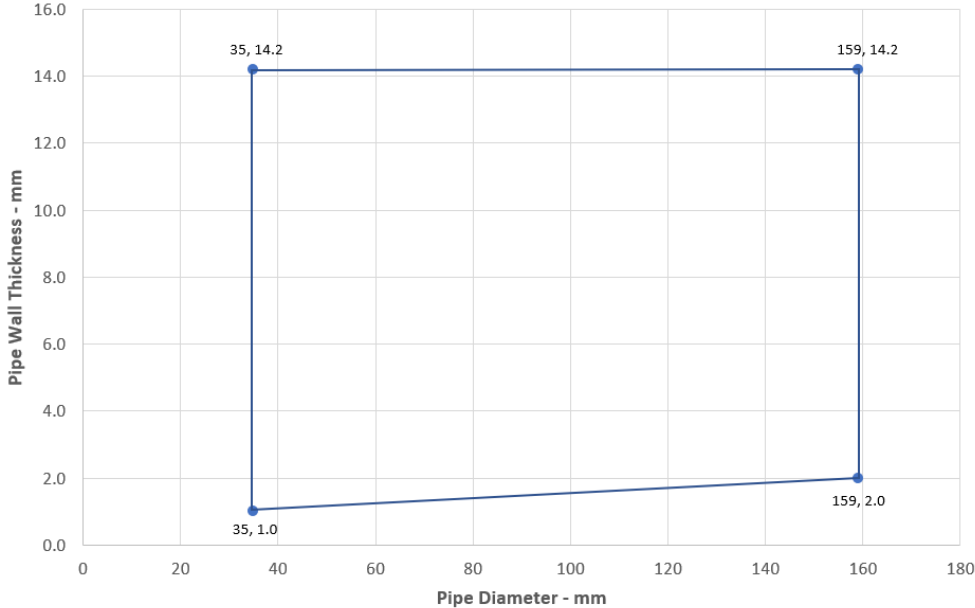

A.5 Rigid floor constructions with floor depth of minimum 150 mm

A.5.1 Penetration seal with metallic pipes

Penetration Seal: Metallic pipes (single) fitted within the aperture, sealed with Pyrocoustic® sealant on the top side of the floor, backed with Stone wool or ceramic wool ($\geq 145 \text{ mm } \geq 45 \text{ kg/m}^3$). Minimum separation between penetration seals 200 mm (a2).

Construction details:

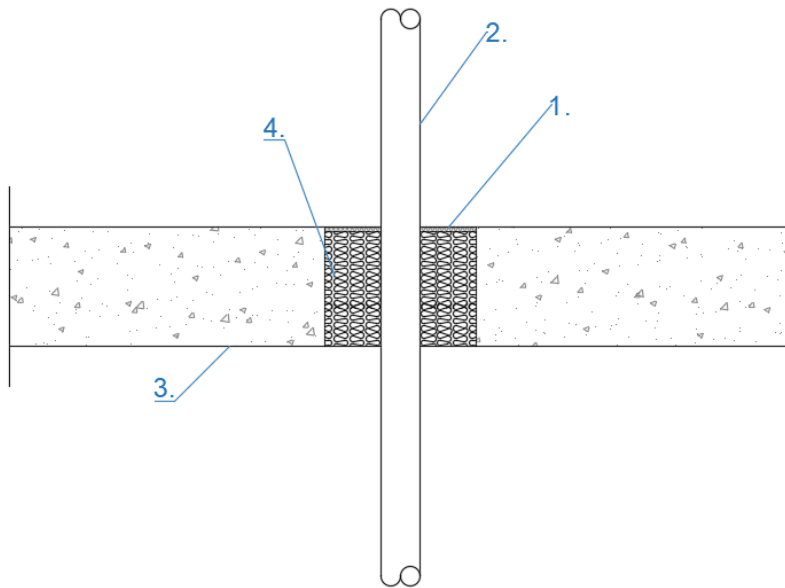

Key:

1. Pyrocoustic® Sealant
2. Metal Pipe
3. Rigid Floor
4. Backing Material

A.5.1.1

Penetration Service	Depth (mm)	Maximum Aperture Size (mm)	Backing Material	Minimum Distance to Edge of Aperture (mm)	Classification
Copper or steel pipe 42-159 mm diameter/ 1-14.2 mm wall thickness	5	200 x 200	Stone wool or ceramic wool ($\geq 145 \text{ mm } \geq 45 \text{ kg/m}^3$)	20	E 180 C/U, C/C
Copper or steel pipe 42 mm diameter/ 1-14.2 mm wall thickness					E 240 C/U, C/C

A.5.2 Penetration seal with cables

Penetration Seal: Cables and conduits fitted at any position within the aperture, sealed with Pyrocoustic® sealant to the top side of the floor, backed with Stone wool or ceramic wool ($\geq 145 \text{ mm } \geq 45 \text{ kg/m}^3$). Minimum separation between penetration seals 200 mm (a2).

Construction details:

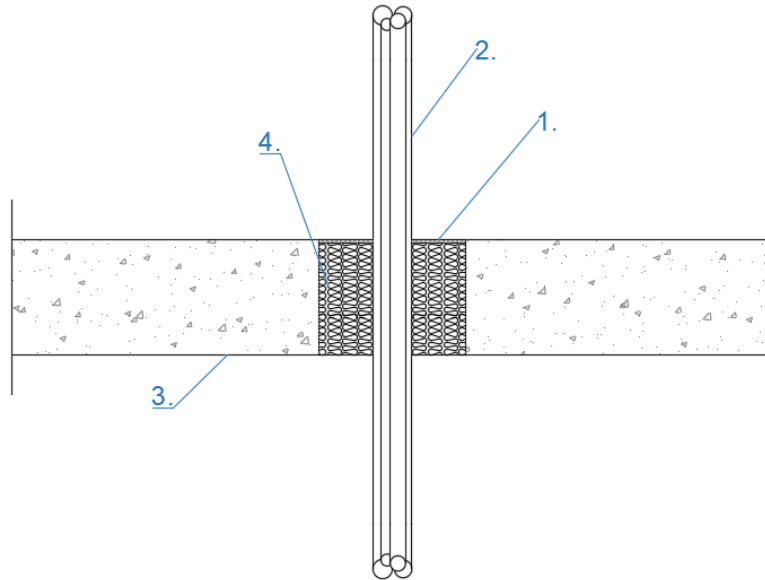

Key:

1. Pyrocoustic® Sealant
2. Cables
3. Rigid Floor
4. Backing Material

A.5.2.1

Penetration Service	Depth (mm)	Maximum Aperture Size (mm)	Backing Material	Minimum Distance to Edge of Aperture (mm)	Classification
Telecoms cables ≤ 21 mm diameter in cable bunch ≤ 100 mm diameter	5	200 x 200	Stone wool or ceramic wool ($\geq 145 \text{ mm } \geq 45 \text{ kg/m}^3$)	0	E 45, EI 15
PVC conduits ≤ 16 mm diameter					E 45, EI 15
Steel or copper conduits ≤ 16 mm diameter					E 45, EI 15
Cables ≤ 80 mm diameter					E 90, EI 45
Cables ≤ 50 mm diameter					E 90, EI 45
Cables ≤ 21 mm diameter					E 240, EI 90

ANNEX B – Air Permeability - Pyrocoustic®

Product tested	25 mm thick x 30 mm wide Pyrocoustic® intumescent sealant		
	Summary of testing procedure		Result
	Pressure (Pa)	Leakage (m³/h)	Leakage (m³/m²/h)
Results under negative chamber pressure	50	0.0	0.0
	100	0.0	0.0
	150	0.1	2.8
	200	0.1	2.8
	250	0.1	2.8
	300	0.0	0.0
	450	0.1	2.8
	600	0.1	2.8
Results under positive chamber pressure	50	0.0	0.0
	100	0.0	0.0
	150	0.0	0.0
	200	0.0	0.0
	250	0.0	0.0
	300	0.0	0.0
	450	0.1	2.8
	600	0.1	2.8

ANNEX C – Airborne Sound Insulation - Pyrocoustic®

C.1 Pyrocoustic® sealant at 15 mm deep in the following configuration

**PYROCOUSTIC® SEALANT TESTED TO EN 10140-2:2010
THROUGH A FLEXIBLE CONSTRUCTION**

ACOUSTIC TEST RESULTS	
Partition & Sealant Result	63 Rw dB
Sealant Result	51 Rw dB
Sealant Result	61 Dnew dB

The diagram illustrates a cross-section of a wall assembly. It consists of two vertical construction elements (3) with a hatched pattern, separated by a central cavity. The cavity is filled with stone wool insulation (2) and a Pyrocoustic sealant (1) applied to one side of the wall. The sealant is shown as a dark, wavy line. The stone wool insulation is shown as a hatched area. The construction elements are shown as hatched areas. The sealant is applied to one side of the wall, and the stone wool insulation is applied to the other side. The sealant is applied to one side of the wall, and the stone wool insulation is applied to the other side. The sealant is applied to one side of the wall, and the stone wool insulation is applied to the other side.

1 - PYROCOUSTIC SEALANT TO ONE SIDE OF WALL 15mm DEPTH
 2 - 55mm DEPTH STONE WOOL 60kg DENSITY
 3 - CONSTRUCTING ELEMENT RATED TO 65 dB

BWR 5 Protection against noise		
Assessment method	Essential characteristic	Product performance
EN 10140-1,2,4,5/ EN ISO 717-1	Airborne sound insulation	Rw (C;Ctr)= 63(-1;-7)

C.2 Pyrocoustic® sealant at 25 mm deep in the following configuration

PYROCOUSTIC® SEALANT TESTED TO EN 10140-2:2010 THROUGH A FLEXIBLE CONSTRUCTION

ACOUSTIC TEST RESULTS	
Partition & Sealant Result	63 Rw dB
Sealant Result	51 Rw dB
Sealant Result	61 Dnew dB

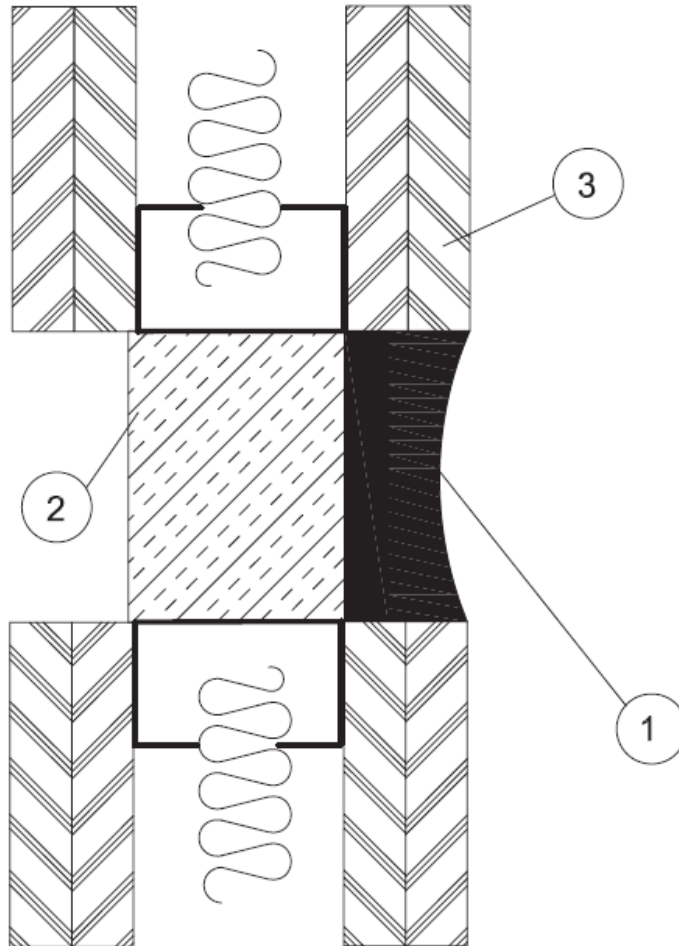

- 1 - PYROCOUSTIC SEALANT TO ONE SIDE OF WALL 25mm DEPTH
- 2 - 55mm DEPTH STONE WOOL 60kg DENSITY
- 3 - CONSTRUCTING ELEMENT RATED TO 65 dB

BWR 5 Protection against noise		
Assessment method	Essential characteristic	Product performance
EN 10140-1,2,4,5/ EN ISO 717-1	Airborne sound insulation	Rw (C;Ctr)= 63(-1;-7)